

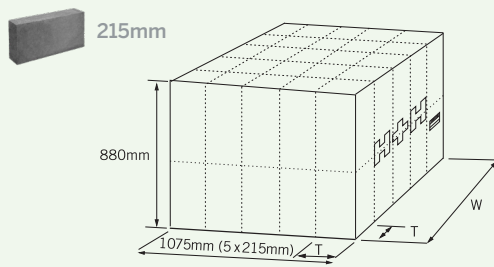

Pack Information

1200mm pallet size

Celcon Blocks & Celcon Foundation Blocks (440mm x 215mm)



Block Thickness (mm) = T	75	100	140	150	200	215	275	300	355
Blocks/m² laid 9.88 (10mm joints)									
Coverage per pack (m²)	16	12	8	8	6	5	4	4	3
Number of blocks per pack	160	120	80	80	60	50	40	40	30
Pack width (mm) = W	1200	1200	1120	1200	1200	1075	1100	1200	1065
Pack weight – Solar Grade (kg)*	-	660	-	-	-	590	-	-	-
Pack weight – Standard Grade (kg)*	875	875	815	875	875	785	800	875	775
Pack weight – High Strength (kg)*	-	1175	1095	1175	1175	1055	1075	1175	1045

Celcon Foundation Blocks (325mm x 215mm)

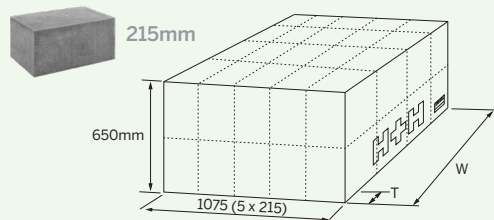

Block Thickness (mm) = T	75	100	140	150	200	215	275	300	355
Blocks/m² laid 13.27 (10mm joints)									
Coverage per pack (m²) – 10mm joint	-	-	-	-	-	-	-	2.6	-
Number of blocks per pack	-	-	-	-	-	-	-	40	-
Pack width (mm) = W	-	-	-	-	-	-	-	1075	-
Pack weight – Standard Grade (kg)*	-	-	-	-	-	-	-	640	-
Pack weight – High Strength/ Super Strength (kg)*	-	-	-	-	-	-	-	740	-

Celcon Plus Blocks (630mm x 215mm)

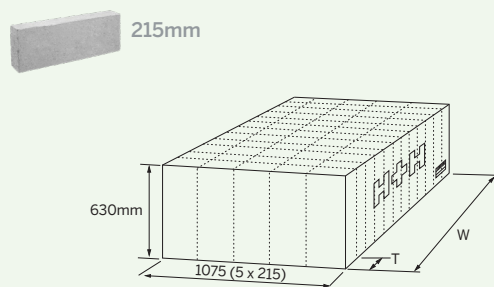

Block Thickness (mm) = T	75	100	140	150	200	215	275	300	355
Blocks/m² laid 6.94 (10mm joints)									
7.29 (2mm joints)									
Coverage per pack (m²) – 10mm joint	-	8.6	5.8	5.8	4.3	-	-	-	-
Coverage per pack (m²) – 2mm joint	-	8.2	5.5	5.5	4.1	-	-	-	-
Number of blocks per pack	-	60	40	40	30	-	-	-	-
Pack width (mm) = W	-	1200	1120	1200	1200	-	-	-	-
Pack weight – Solar Grade (kg)*	-	470	440	470	470	-	-	-	-
Pack weight – Standard Grade (kg)*	-	620	575	620	620	-	-	-	-
Pack weight – High Strength/ Super Strength (kg)*	-	720	670	720	720	-	-	-	-



Pack Information

1200mm pallet size

Jumbo Bloks (630mm x 250mm)

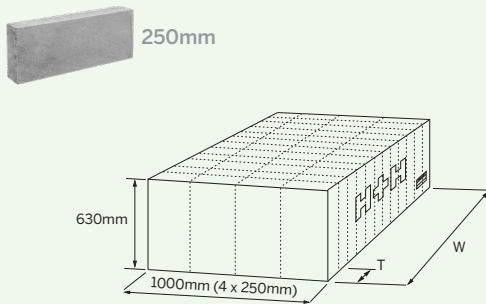

Block Thickness (mm) = T	75	100	140	150	200	215	275	300	355
Blocks/m² laid 6.28 (2mm joints)									
Coverage per pack (m²) – 2mm joint	-	76	51	-	-	-	-	-	-
Number of blocks per pack	-	48	32	-	-	-	-	-	-
Pack width (mm) = W	-	1200	1120	-	-	-	-	-	-
Pack weight – Solar Grade (kg)*	-	440	410	-	-	-	-	-	-
Pack weight – Standard Grade (kg)*	-	575	535	-	-	-	-	-	-
Pack weight – High Strength/ Super Strength (kg)*	-	670	625	-	-	-	-	-	-

Celcon Coursing Units (215mm x 65mm x 100mm)

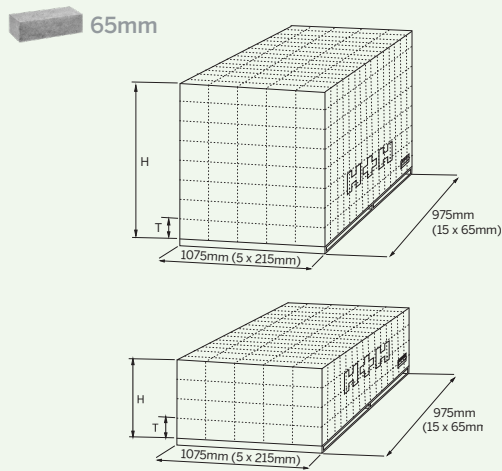

Coverage per pack (m²) – 10mm joint	-	10.1	5.1	5.1	-	-	-	-	-
Coverage per pack (m²) – 2mm joint	-	8.7	4.4	4.4	-	-	-	-	-
Number of blocks per pack	-	600	300	300	-	-	-	-	-
Pack height (mm) = H	-	800	560	600	-	-	-	-	-
Pack weight – Standard Grade (kg)*	-	645	455	485	-	-	-	-	-
Pack weight – High Strength/ Super Strength (kg)*	-	870	610	650	-	-	-	-	-

* Pack weight excludes pallet



For further information and to check our most up-to-date product range, or to find your nearest stocking merchant, please visit our website www.hhcelcon.co.uk or contact the following departments:

Sales

For sales enquiries or to find your local stockist please contact
Tel: 01732 886444 Fax: 01732 887013

Technical

For technical enquiries please contact
Tel: 01732 880580 Fax: 01732 887013